

WS2200-180DMS WINKELSCHLEIFER IN2

4935428490 - WS2200-180DMS - 4000428491

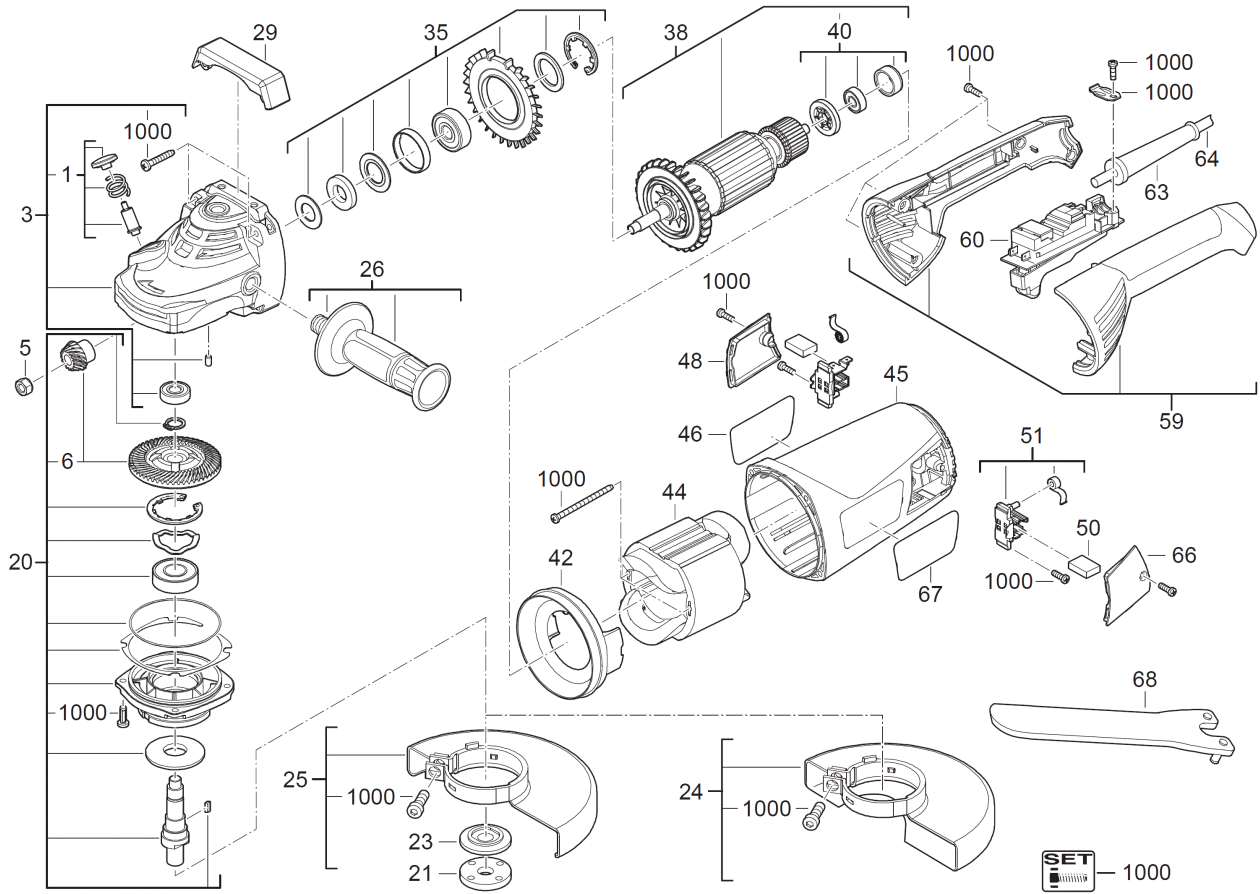

Position	Quantity	Description	Part number	EAN
0001 1	1	DRUECKER	4931428850	4002395849970
0003 2	1	GETRIEBEKASTEN	4931428851	4002395849987
0005 3	1	MUTTER	4931428852	4002395849994
0006 4	1	GETRIEBESATZ	4931428497	4002395858767
0020 5	1	SPINDEL SATZ	4931428894	4002395848089
0021 6	1	FLANSCHMUTTER M14	4931428854	4002395850013
0023 7	1	FLANSCH	4931428855	4002395850020
0024 8	1	SCHUTZHAUBEN-SET	Item discontinued(4931428856)	
0025 9	1	SCHUTZ	4931428858	4002395847884
0026 10	1	ZUSATZHANDGRIFF	4931428860	4002395850037
0029 11	1	HALTER	4931428861	4002395850044
0035 12	1	Luftfuehrungsring + Kugellager	4931428862	4002395848713
0038 13	1	ANKER F.ELEKTROMOTOR	4931428863	4002395850051
0040 14	1	KUGELLAGER	4931428864	4002395850068
0042 15	1	LUFTFUEHRUNGSRING	4931428865	4002395850075
0044 16	1	FELD F. ELEKTROMOTOR	4931428866	4002395850082
0045 17	1	MOTORGEHAEUSE	4931428867	4002395850099
0046 18	1	LEISTUNGSSCHILD	Item discontinued(4931428870)	
0048 19	1	BUERSTENHALTERKAPPE	4931428872	4002395847341
0050 20	1	KOHLEBUERSTEN-SET	4931433523	4002395894055
0051 21	1	BUERSTENHALTER-PAAR	4931428874	4002395847365
0059 22	1	HANDGRIFF KOMPL.	4931428876	4002395847389
0060 23	1	SCHALTER	4931428878	4002395848003
0063 24	1	KABELSCHUTZSCHLAUCH	4931428879	4002395848010
0064 25	1	ANSCHLUSSLEITUNG	4931428880	4002395848027
0066 26	1	BUERSTENHALTERKAPPE	4931428881	4002395848034
0067 27	1	FIRMENSCHILD	4931428882	4002395848041
0068 28	1	SCHLUESSEL	4931428883	4002395848058
1000 29	1	SCHRAUBENSET	4931428884	4002395848065