

# **WS10-115 Winkelschleifer ME2**

**4935451299 - WS10-115 - 4000456096**

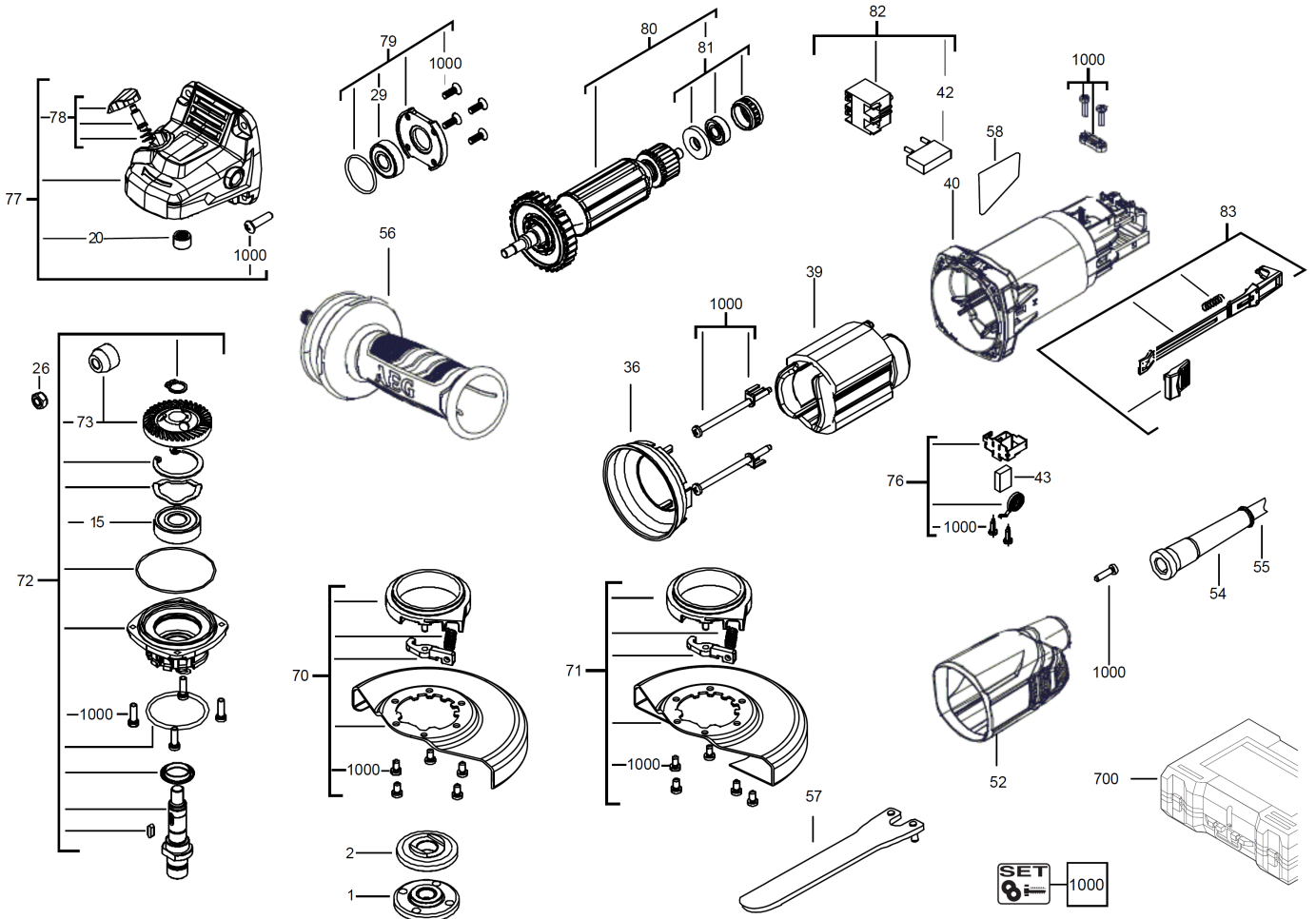

Position	Quantity	Description	Part number	EAN
0001 1	1	FLANSCH	4931428704	4002395844210
0002 2	1	FLANSCH	4931453620	4002395145942
0015 3	1	KUGELLAGER	4931453697	4002395146130
0020 4	1	NADELLAGER	4931453616	4002395145904
0026 5	1	MUTTER	4931428715	4002395844364
0029 6	1	KUGELLAGER	4931453633	4002395146673
0036 7	1	LUFTFUEHRUNGSRING	4931428721	4002395844425
0039 8	1	FELD F. ELEKTROMOTOR	4931428723	4002395844449
0040 9	1	MOTORGEHAEUSE	4931453698	4002395146147
0042 10	1	KONDENSATOR	4931428728	4002395844494
0043 11	2	KOHLEBUERSTE	4931428732	4002395844531
0052 12	1	ABDECKKAPPE	4931453699	4002395146154
0054 13	1	KABELSCHUTZSCHLAUCH	4931428735	4002395844562
0055 14	1	ANSCHLUSSLEITUNG	4931428736	4002395844579
0056 15	1	HANDGRIFF	4931428739	4002395844609
0057 16	1	MUTTERNDREHER	4931393248	4002395751051
0058 17	1	LEISTUNGSSCHILD	4931453701	4002395146178
0070 18	1	SCHUTZ	4931428707	4002395844241
0071 19	1	SCHNEIDHILFE	4931428710	4002395844265
0072 20	1	SPINDEL SATZ	4931428712	4002395844333
0073 21	1	RITZEL	4931441558	4002395865710
0076 22	2	BUERSTENHALTER	4931428733	4002395844548
0077 23	1	GETRIEBEKASTEN	4931428713	4002395844340
0078 24	1	VERSCHLUSSKAPPE	4931428714	4002395844357
0079 25	1	LAGERSATZ	4931428716	4002395844371
0080 26	1	ANKER F.ELEKTROMOTOR	4931453706	4002395146826
0081 27	1	LAGERSATZ	4931428720	4002395844418
0082 28	1	ELEKTRONIKSCHALTER	Item discontinued(4931453707)	
0083 29	1	SCHALTHEBEL	4931453708	4002395146840
0700 30	1	TRANSPORTKASTEN	4931453709	4002395146857
1000 31	1	SCHRAUBENSET	4931428741	4002395844623