

WS13-125SXEK WINKELSCHLEIFER IN2

4935451310 - WS13-125SXEK - 4000504108

AEG 4000504104
4000504108

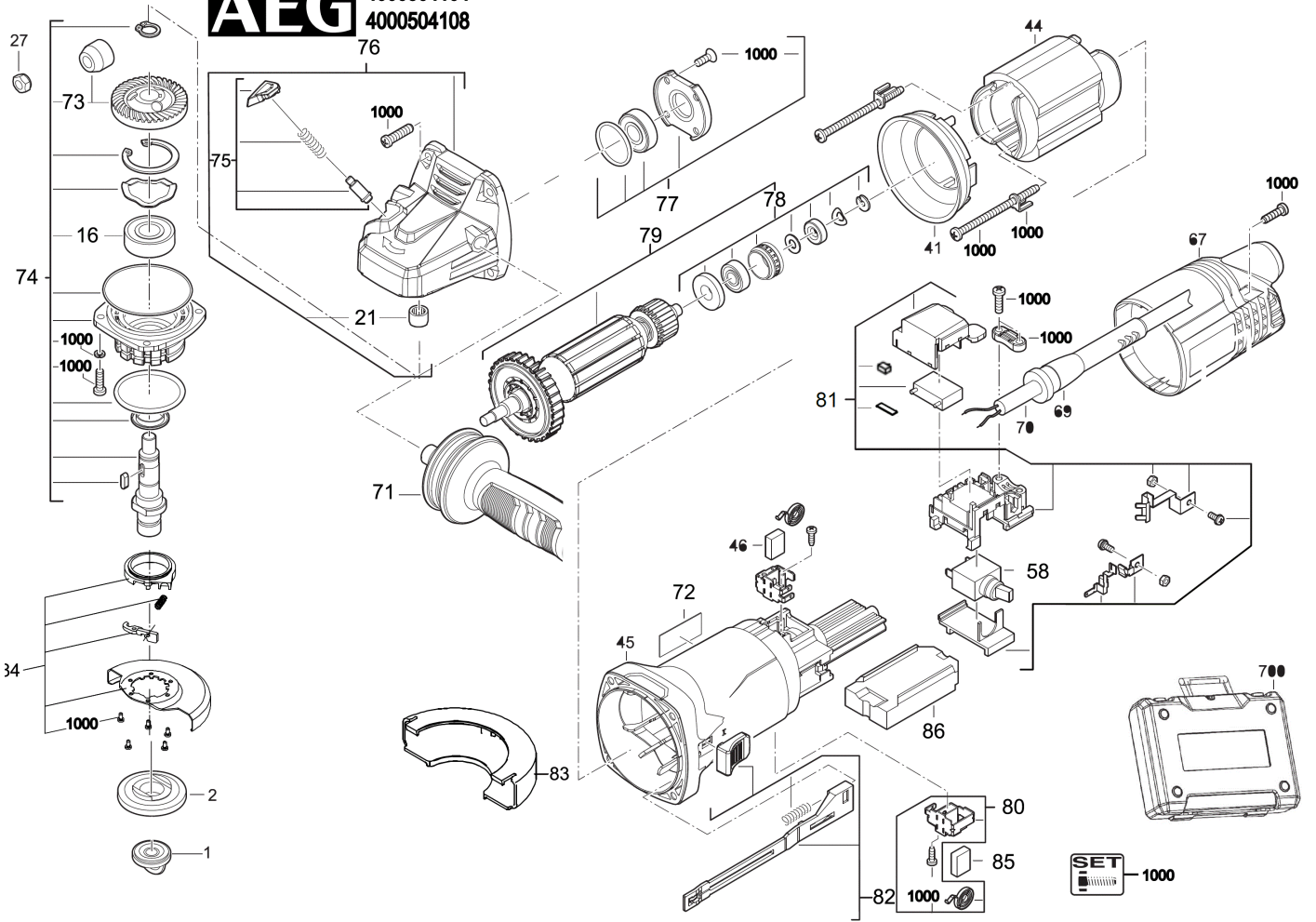

Position	Quantity	Description	Part number	EAN
0001 1	1	FIXTEC-MUTTER	4931508096	4058546627584
0002 2	1	FLANSCH	4931453620	4002395145942
0016 3	1	KUGELLAGER	4931453697	4002395146130
0021 4	1	NADELLAGER	4931453616	4002395145904
0027 5	1	MUTTER	4931428715	4002395844364
0041 6	1	LUFTFUEHRUNGSRING	4931508097	4058546627591
0044 7	1	FELD F. ELEKTROMOTOR	4931508098	4058546627607
0045 8	1	MOTORGEHAEUSE	4931453724	4002395141418
0046 9	2	KOHLEBUERSTE	4931428732	4002395844531
0058 10	1	SCHALTER	4931428762	4002395847570
0067 11	1	GEHAEUSE	4931453725	4002395141425
0069 12	1	KABELSCHUTZSCHLAUCH	4931428735	4002395844562
0070 13	1	ANSCHLUSSLEITUNG	4931453726	4002395141432
0071 14	1	HANDGRIFF	4931428739	4002395844609
0072 15	1	LEISTUNGSSCHILD	Item discontinued(4931508100)	
0073 16	1	ANTRIEB	4931508084	4058546627461
0074 17	1	SPINDEL SATZ	4931508083	4058546627454
0075 18	1	ARRETIERBOLZEN	4931508086	4058546627485
0076 19	1	GETRIEBEKASTEN	4931508087	4058546627492
0077 20	1	LAGERSATZ	4931508088	4058546627508
0078 21	1	LAGER	4931508103	4058546627652
0079 22	1	ANKER F.ELEKTROMOTOR	4931508104	4058546627669
0080 23	2	BUERSTENHALTER	4931508085	4058546627478
0081 24	1	SCHALTER	4931453733	4002395142118
0082 25	1	SCHALTHEBEL	4931453729	4002395141470
0083 26	1	TRENNSCHUTZHAUBE	4931508075	4058546627379
0084 27	1	SCHUTZ	4931428708	4002395844272
0086 28	1	SCHALTER M.ELEKTRO.	4931453734	4002395142125
0700 29	1	TRANSPORTKASTEN	4931453709	4002395146857
1000 30	1	SCHRAUBENSET	Item discontinued(4931428742)	