

5446-21"SDS-M/500S120V USA GE -60HZ

4933405695 - 5446-21 - 4000405696

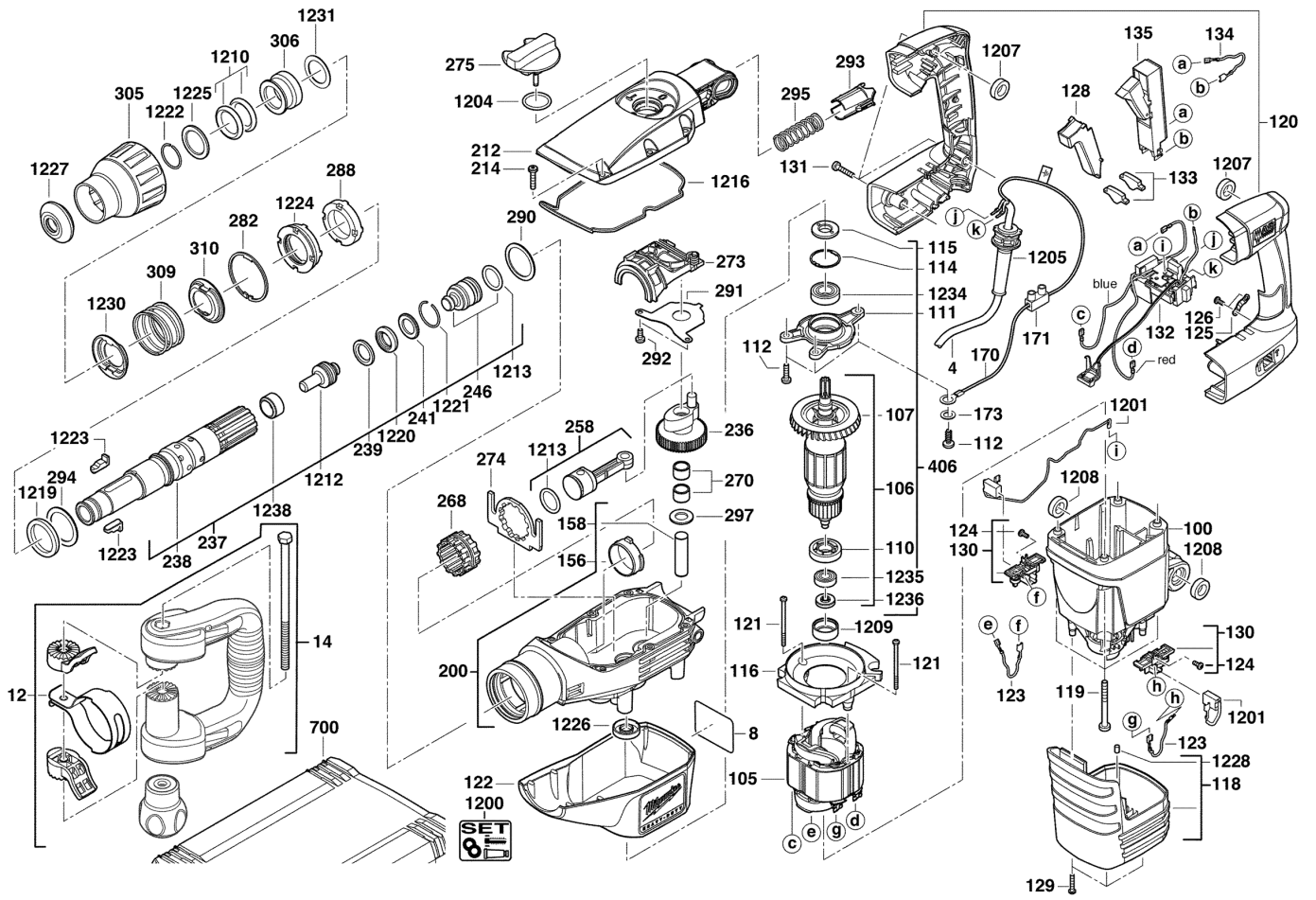

Position	Quantity	Description	Part number	EAN
0004 1	1	ANSCHLUSSLEITUNG	4931624637	4002395788590
0008 2	1	LEISTUNGSSCHILD	Item discontinued(4931405701)	
0012 3	1	SPANNBAND	4931398272	4002395764877
0014 4	1	HANDGRIFF KOMPL.	4931398238	4002395766338
0100 5	1	MOTORGEHAUSE MI-RT	4931398203	4002395759354
0105 6	1	FELD F. ELEKTROMOTOR	4931442748	4002395885251
0106 7	1	ANKER F.ELEKTROMOTOR	Item discontinued(4931398574)	
0107 8	1	VENTILATOR	4931398185	4002395767168
0110 9	1	STAUBDICHTUNG	4931398508	4002395768714
0111 10	1	LAGERSCHILD	4931426441	4002395842131
0112 11	3	SCHRAUBE	4931624541	4002395762019
0114 12	1	SPERRING	4931890311	4002395706297
0115 13	1	DICHTRING	4931398198	4002395767281
0116 14	1	LUFTFUEHRUNGSRING M BOHRUNG	4931405703	4002395787289
0118 15	1	MOTORKAPPE	4931398204	4002395759361
0119 16	4	SCHRAUBE	4931624542	4002395762026
0120 17	1	HANDGRIFFSCHAL.PAAR	4931398208	4002395759385
0121 18	2	SCHRAUBE	4931339996	4002395623976
0122 19	1	GETRIEBEKASTENISOL.	4931398206	4002395759378
0123 20	2	LEITUNG	4931624263	4002395724819
0124 21	4	SCHRAUBE	4931624538	4002395760039
0125 22	1	KABELSCHELLE	4931256500	4002395586547
0128 23	1	DRUECKERKAPPE	4931398529	4002395776603
0129 24	4	SCHRAUBE	4931624517	4002395757381
0130 25	2	BUERSTENHALTER	4931381694	4002395780303
0131 26	3	SCHRAUBE	4931624504	4002395756148
0132 27	1	ELEKTRONIK	4931409088	4002395788514
0133 28	2	LICHTLEITER	4931398114	4002395756063
0134 29	1	KABEL	4931624681	4002395793938
0135 30	1	SCHALTER	4931375454	4002395731688
0156 31	1	LAGER	4931398095	4002395753475
0158 32	1	LAGERBOLZEN	4931398746	4002395789955
0170 33	1	LEITUNG	Item discontinued(4931624636)	
0171 34	1	KLEMME	Item discontinued(4931409087)	
0173 35	1	RING	Item discontinued(4931603756)	
0200 36	1	GETRIEBEKASTEN	4931409532	4002395819034
0212 37	1	GETRIEBEBEDECKEL MI-SI	4931426453	4002395846467
0214 38	6	SCHRAUBE	4931624555	4002395764136
0236 39	1	KURBELRAD	4931409600	4002395825295
0237 40	1	SPINDEL	4931398026	4002395764037
0238 41	1	SPINDELHUELSE M	4931417457	4002395833450
0239 42	1	RUECKSCHLAGRING	4931398031	4002395755790
0241 43	1	SCHEIBE	4931398032	4002395755806
0246 44	1	SCHLAGKOERPER	4931455433	4002395177103
0258 45	1	KOLBEN KOMPL.	4931398747	4002395789788
0268 46	1	STELLRING	4931398078	4002395755769
0270 47	2	NADELLAGER	4931621847	4002395696192
0273 48	1	STELLELEMENT	4931398154	4002395760053
0274 49	1	ARRETIERBLECH	4931398075	4002395755936
0275 50	1	UMSCHALTER	4931398626	4002395788651

Position	Quantity	Description	Part number	EAN
0282 51	1	RING	4931624479	4002395755950
0288 52	1	TRAGRING	4931398091	4002395753451
0290 53	2	SCHEIBE	4931624499	4002395755967
0291 54	1	HALTEBLECH	4931398658	4002395787852
0292 55	2	SCHRAUBE	4931624236	4002395717477
0293 56	1	DRUCKSTUECK	4931398097	4002395755974
0295 57	1	DRUCKFEDER	4931398099	4002395755981
0297 58	1	SCHEIBE	4931624535	4002395760404
0305 59	1	HUELSE	4931398216	4002395759392
0306 60	1	VERRIEGEL.-HUELSE	4931426248	4002395838707
0309 61	1	DRUCKFEDER VERRIEGELUNG12/2005	4931398856	4002395794324
0310 62	1	ABDECKKAPPE	4931426013	4002395846009
0406 63	1	ANKER M LAGERSCHILD 110-120V LH	4931449972	4002395171736
0700 64	1	TRANSPORTKASTEN	4931455773	4058546041052
1200 65	1	WART-SET 5446/5426-21 14-46-0290	4931409243	4002395789542
1201 66	1	KOHLEBUERSTEN-SET	4931398132	4002395757312
1204 67	1	O-RING	4931622166	4002395696963
1205 68	1	KABELSCHUTZSCHLAUCH	4931387206	4002395746798
1207 69	2	DAEMPUNGSELEMENT	4931398748	4002395789917
1208 70	2	DAEMPFUNGSBUCHSE	4931398101	4002395754588
1209 71	1	GUMMIBUCHSE	4931398085	4002395753291
1210 72	2	DICHTRING	4931624440	4002395755226
1212 73	1	DOEPFER	4931398578	4002395787470
1213 74	2	O-RING	4931398297	4002395767175
1216 75	1	DICHTUNG	4931398539	4002395776665
1219 76	1	DAEMPUNGSELEMENT	4931398105	4002395755776
1220 77	1	FANGRING	4931398033	4002395755660
1221 78	1	RING	4931398073	4002395768141
1222 79	1	SPRENGRING	9170319040	4002395571895
1223 80	2	VERRIEGEL.-ELEMENT	4931487601	4058546541422
1224 81	1	DICHTUNGSHALTER	4931398034	4002395758586
1225 82	1	VERRIEGEL.-SCHEIBE	4931398080	4002395755899
1226 83	1	DICHTRING	4931624495	4002395755400
1227 84	1	GUMMIKAPPE	4931398064	4002395755677
1228 85	1	NIEDERHALTER	4931409768	4002395847617
1230 86	1	VERRIEGELUNGSBLECH	4931426013	4002395846009
1231 87	1	SCHEIBE	4931398298	4002395768127
1234 88	1	RILLENKUGELLAGER	4931398189	4002395767304
1235 89	1	KUGELLAGER	4931341741	4002395627004
1236 90	1	MAGNETSCHEIBE	4931426570	4002395856497
1238 91	1	BREMSRING	4931409781	4002395841813