

# FSPE110X PENDELHUBSTICHSÄGE IN2

4933357990 - FSPE110X - 4000415249

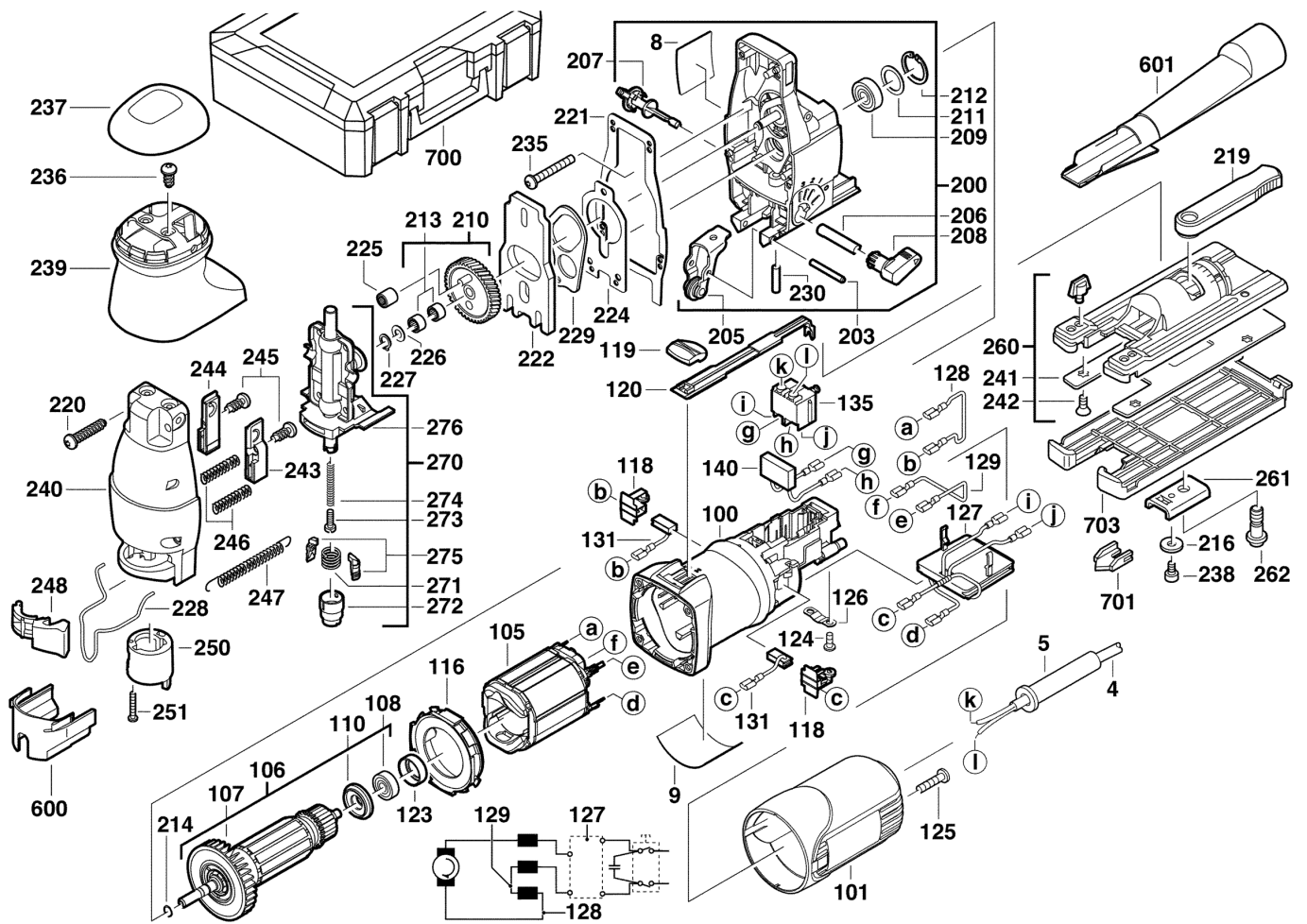



Position	Quantity	Description	Part number	EAN
0004 1	1	ANSCHLUSSLEITUNG	4931624121	4002395705627
0005 2	1	KABELSCHUTZSCHLAUCH	4931206687	4002395583379
0009 3	1	LEISTUNGSSCHILD	4931476708	4058546391546
0100 4	1	MOTORGEHAEUSE MI-RT	4931403002	4002395755424
0101 5	1	GEHAEUSEKAPPE	4931403010	4002395755561
0105 6	1	FELD F. ELEKTROMOTOR	4931426479	4002395843565
0106 7	1	ANKER 220-240V 32X48	4931442641	4002395884445
0107 8	1	VENTILATOR	Item discontinued(4931368347)	
0108 9	1	KUGELLAGER	4931902888	4002395706372
0110 10	1	ISOLIERSCHEIBE	4931385658	4002395719846
0116 11	1	LUFTFUEHRUNGSRING	4931368332	4002395671434
0118 12	2	BUERSTENHALTER	4931368633	4002395746545
0119 13	1	SCHIEBER	4931381347	4002395720859
0120 14	1	FUEHRUNGSSTUECK	4931368386	4002395716890
0123 15	1	GUMMIBUCHSE	4931368374	4002395671601
0124 16	2	SCHRAUBE	4931624538	4002395760039
0125 17	2	SCHRAUBE	4931618253	4002395694945
0126 18	1	KABELSCHELLE	4931256500	4002395586547
0127 19	1	ELEKTR.BAUSTEIN	4931357989	4002395711352
0128 20	1	LEITUNG	4931624081	4002395705467
0129 21	1	LEITUNG	4931253598	4002395586134
0131 22	1	KOHLBUERSTEN-SET	4931392611	4002395740628
0135 23	1	SCHALTER	4931368387	4002395709151
0140 24	1	KONDENSATOR	4931403213	4002395759668
0200 25	1	GETRIEBEKASTEN	4931412831	4002395799459
0203 26	1	SPANNSTIFT	4931621942	4002395696307
0205 27	1	STUETZROLLENHALTER VOLLST	4931468106	4058546268923
0206 28	1	SCHALTBOLZEN	4931381103	4002395709397
0207 29	1	UMSCHALTER	4931381156	4002395713424
0208 30	1	SCHALTGRIFF	4931378812	4002395684762
0209 31	1	KUGELLAGER	4931901253	4002395706358
0210 32	1	ZAHNRAD	4931357515	4002395649549
0211 33	1	AUSGLEICHSSCHEIBE	4931803914	4002395705856
0212 34	1	SICHERUNGSRING	4931613683	4002395694181
0213 35	2	NADELLAGER	4931219422	4002395583867
0214 36	1	SPERRING	4931621828	4002395696130
0216 37	1	SCHEIBE	4931622131	4002395696857
0219 38	1	SPANNHEBEL	4931381610	4002395737079
0220 39	4	SCHRAUBE	4931623020	4002395700073
0221 40	1	Dichtung	4931381656	4002395746538
0222 41	1	AUSGLEICHSMASSE	4931381109	4002395709403
0224 42	1	UNTERLEGBLECH	4931357577	4002395649730
0225 43	1	NADELHUELSE	4931361376	4002395657766
0226 44	1	SCHEIBE	4931621830	4002395696154
0227 45	1	SICHERUNGSRING	4931605092	4002395693580
0228 46	1	DRAHTBUEGEL	4931357982	4002395711079
0229 47	1	SCHWINGE	4931357522	4002395649563
0230 48	1	ZYLINDERSTIFT	4931381112	4002395711062
0235 49	4	SCHRAUBE	4931621515	4002395695508
0236 50	2	SCHRAUBE	4931623048	4002395700189

Position	Quantity	Description	Part number	EAN
0237 51	1	KNAUFDECKEL	4931330272	4002395611638
0238 52	1	SCHRAUBE	4931300699	4002395591060
0239 53	1	KNAUFGRIFF	4931330271	4002395611621
0240 54	1	GETRIEBEBECKEL	4931426460	4002395844777
0241 55	1	PART NOT DETAILED	1000063920	
0242 56	4	SCHRAUBE	4931310396	4002395721542
0243 57	1	LAGERHALTER LINKS	4931357986	4002395715848
0244 58	1	LAGERHALTER RECHTS	4931357985	4002395715831
0245 59	2	SCHRAUBE	4931317532	4002395600175
0246 60	2	DRUCKFEDER	4931341759	4002395627066
0247 61	1	ZUGFEDER	4931330453	4002395611997
0248 62	1	SCHALTHEBEL	4931381159	4002395713448
0250 63	1	SCHALTHUELSE	4931381158	4002395713431
0251 64	1	SCHRAUBE	4931624172	4002395711178
0260 65	1	BODENPLATTE	4931412827	4002395794058
0261 66	1	DRUCKSTUECK	4931357588	4002395649785
0262 67	1	SCHRAUBE	4931381124	4002395711154
0270 68	1	STOESSEL	4931357693	4002395650026
0271 69	1	DREHFEDER	4931330424	4002395611911
0272 70	1	SPANNHUELSE	4931330494	4002395612079
0273 71	1	SCHRAUBE	4931623102	4002395700394
0274 72	1	DRUCKFEDER	Item discontinued(4931357686)	
0275 73	2	ZENTRIERBACKE	4931330303	4002395611669
0276 74	1	DICHTRING	4931623091	4002395700363
0600 75	1	STAUBKAPPE	4931357987	4002395716845
0601 76	1	ABSAUGSTUTZEN	4931357983	4002395714865
0700 77	1	TRANSPORTKOFFER	4931415345	4002395827985
0703 78	1	GLEITSCHUH JSPE90X P1 A/M	4932430356	4002395380176