

AG16-150XC DMS TOTM-WINKELSCHLEIFER IN2

4933407295 - AG16-150QXC - 4000415309

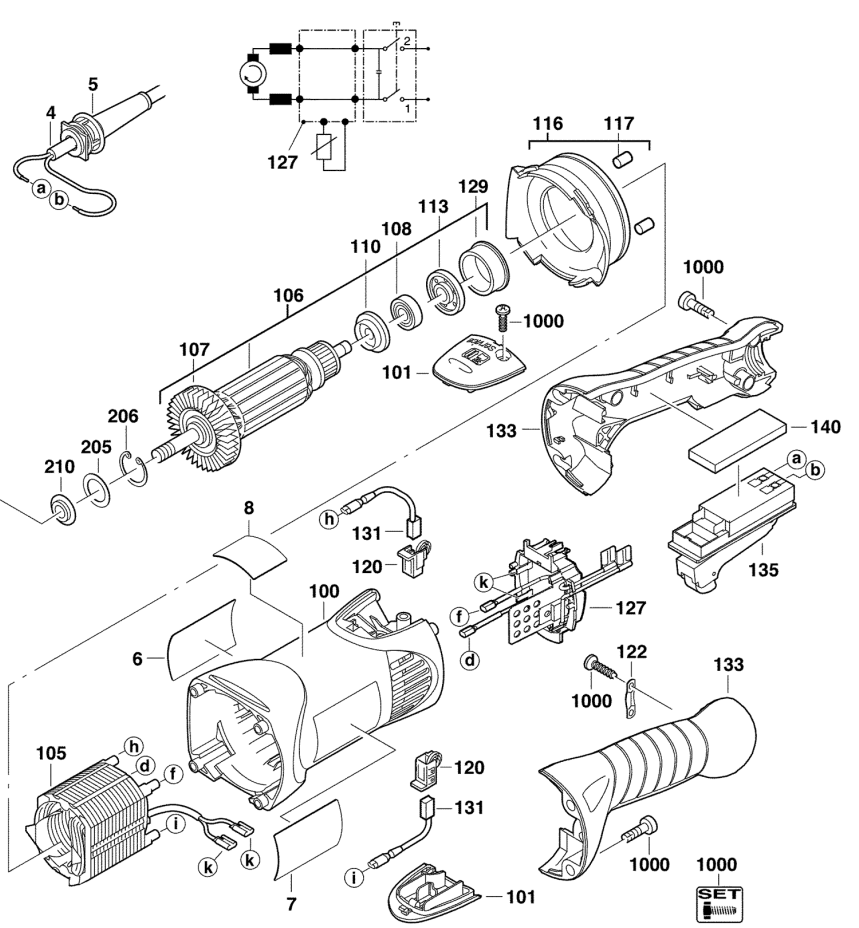

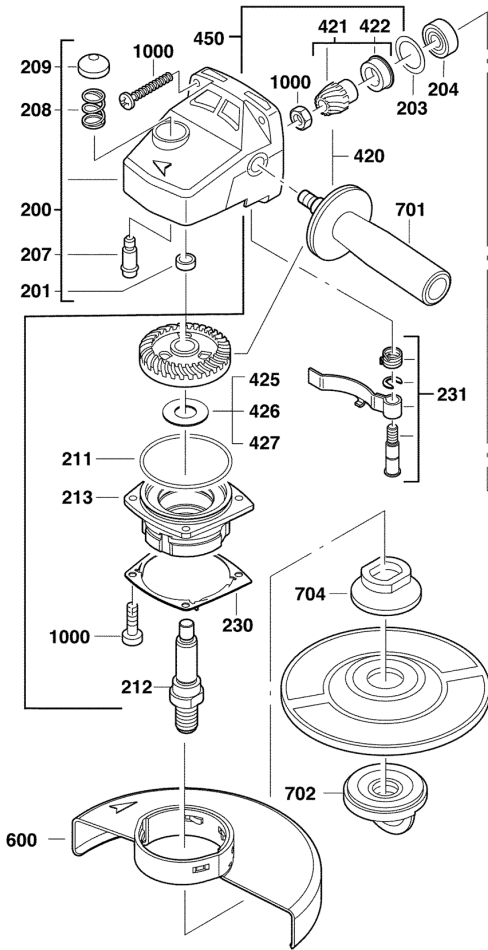

Position	Quantity	Description	Part number	EAN
0004 1	1	ANSCHLUSSLEITUNG	4931623311	4002395701292
0005 2	1	KABELSCHUTZSCHLAUCH	4931409552	4002395801107
0006 3	1	LEISTUNGSSCHILD	4931415310	4002395820733
0007 4	1	TYPENSCHILD	4931378806	4002395684755
0008 5	1	AUFKLEBER	4931442232	4002395873579
0100 6	1	MOTORGEHAEUSE MI-RT	4931378768	4002395684601
0101 7	2	DECKEL	4931378566	4002395684199
0105 8	1	FELD M TEMPERATURF WIRBELSINTERN	4931442727	4002395883295
0106 9	1	ANKER F.ELEKTROMOTOR	4931442662	4002395883196
0107 10	1	VENTILATOR	4931341088	4002395626205
0108 11	1	D 625 KULA 627-2RSL TN9/C3HGWF4	4931624662	4002395790890
0110 12	1	ISOLIERSCHEIBE	4931271823	4002395588138
0113 13	1	MAGNETSCHEIBE	4931426570	4002395856497
0116 14	1	LUFTFUEHRUNGSRING	4931378135	4002395683123
0117 15	2	NIEDERHALTER	4931409768	4002395847617
0120 16	2	BUERSTENHALTER	4931382268	4002395690961
0122 17	1	KABELSCHELLE	4931256500	4002395586547
0127 18	1	ELECTRONIK-BAUSTEIN	4931378141	4002395683161
0129 19	1	LAGERBUECHSE	4931326953	4002395607846
0131 20	1	KOHLEBUERSTEN-SET	4931381391	4002395726936
0133 21	1	HANDGRIFF	4931378762	4002395684588
0135 22	1	SCHALTER	4931378949	4002395685240
0140 23	1	DICHTUNG	4931407251	4002395790760
0200 24	1	GETRIEBEKASTEN	4931407067	4002395789528
0201 25	1	Nadelhuelse	4931912093	4002395706464
0203 26	1	SCHEIBE	4931362085	4002395660254
0204 27	1	RILLENKUGELLAGER	4931368037	4002395670642
0205 28	1	SCHEIBE	4931622761	4002395699056
0206 29	1	SPERRING	4931616614	4002395694624
0207 30	1	ARRETIERBOLZEN	4931326929	4002395607785
0208 31	1	DRUCKFEDER	4931326942	4002395607822
0209 32	1	DRUECKER	4931326930	4002395607792
0210 33	1	SCHEIBE	4931624287	4002395732098
0211 34	1	AUSGLEICHSCHEIBE	4931254894	4002395586448
0212 35	1	SPINDEL M14	4931409809	4002395838691
0213 36	1	LAGERSCHILD	4931407097	4002395812936
0230 37	1	FEDERBLECH	4931426499	4002395845224
0231 38	1	ARRETIERSTUECK	4931407605	4002395819096
0420 39	1	KEGELRADPAAR	4931369887	4002395674398
0421 40	1	RITZEL	4931369887	4002395674398
0422 41	1	DICHTRING	4931369774	4002395674169
0425 42	1	SCHEIBE	4931808473	4002395727544
0426 43	1	SCHEIBE	4931925940	4002395706624
0427 44	1	SCHEIBE	4931624256	4002395723379
0450 45	1	ANTRIEB	4931409561	4002395826216
0600 46	1	SCHUTZHAUBE 150 SW	4931395292	4002395856985
1000 47	1	SCHRAUBENSET	4931378570	4002395684205
0701 48	1	ZUSATZHANDGRIFF	4932409546	4002395370870
0702 49	1	FIXTEC MUTTER AEG M14 SNP	4932358225	4002395325528
0704 50	1	SPANNFLANSCH FUeR WINKELSCHLEIFER	4932449324	4002395245185