

# M18CSX-402C AKKU-SAEBELSAEGE IN2

4933446070 - M18CSX-402C - 4000448972

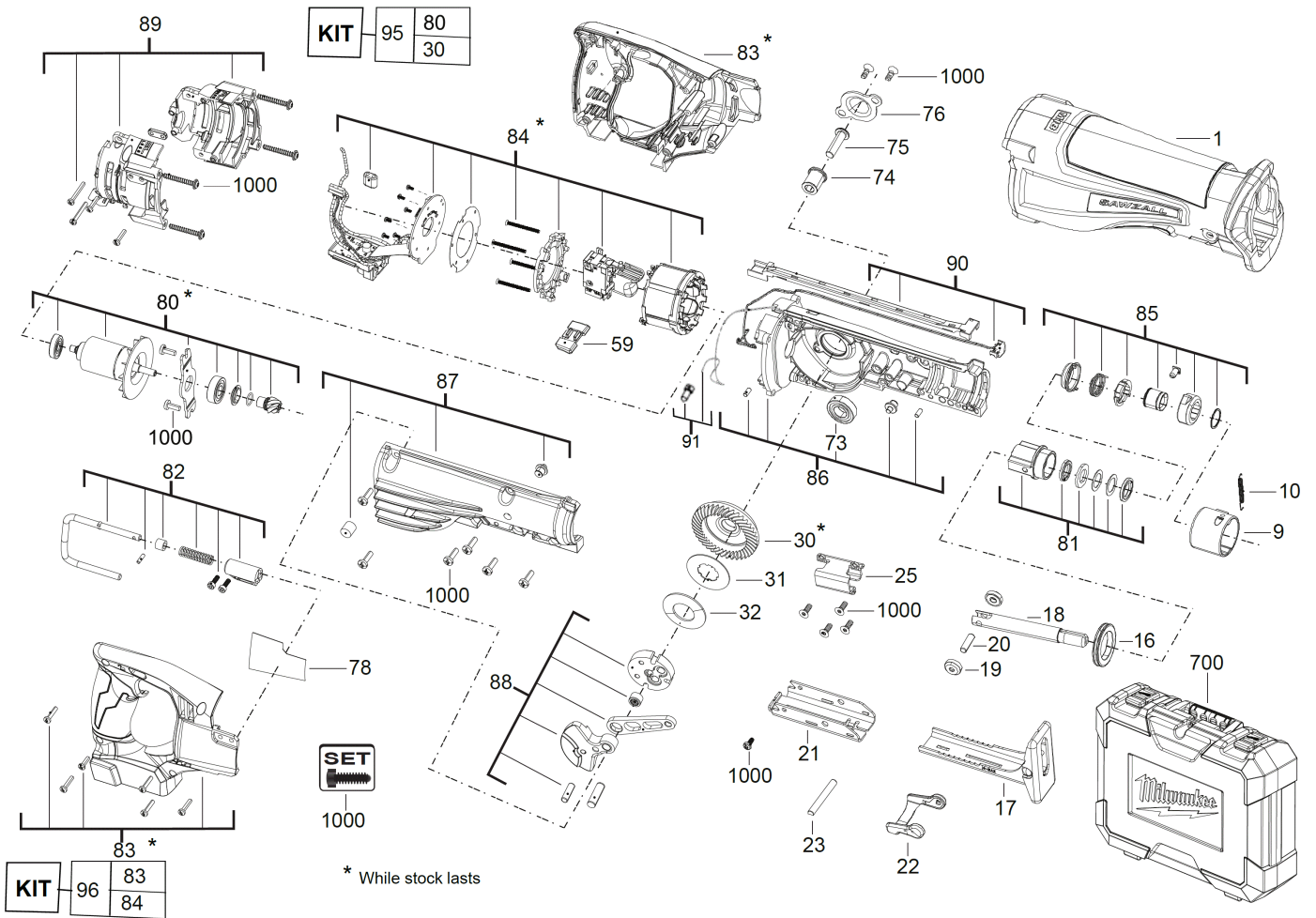



<b>KIT</b>	95	80
		30

<b>KIT</b>	96	83
		84

\* While stock lasts

Position	Quantity	Description	Part number	EAN
0001 1	1	GUMMIFUSS	Item discontinued(4931436052)	
0009 2	1	MITNEHMER	4931436051	4002395876341
0010 3	1	FEDER	4931436050	4002395876334
0016 4	1	DICHTUNG	4931436021	4002395877652
0017 5	1	ABSTANDSHALTER	4931473791	4058546363598
0018 6	1	SPINDEL	4931436023	4002395877676
0019 7	2	ROLLE	4931436024	4002395877683
0020 8	1	AUSGLEICHSMASSE	4931436025	4002395877690
0021 9	1	HALTER	4931436026	4002395878307
0022 10	1	EINSCHALTSPERRE	4931436027	4002395878314
0023 11	1	STIFT	44601635	4058546073930
0025 12	1	STEMPEL	4931436028	4002395878321
0030 13	1	KEGELRAD	Item discontinued(4931436029)	
0031 14	1	PLATTE	4931436030	4002395878345
0032 15	1	Unterlegscheibe	4931436031	4002395878352
0059 16	1	EINSCHALTSPERRE	Item discontinued(4931436053)	
0073 17	1	KUGELLAGER	4931436033	4002395878376
0074 18	1	ABSTANDSHALTER	4931436034	4002395172177
0075 19	1	SCHRAUBE	4931436035	4002395878383
0076 20	1	PLATTE	4931436036	4002395878390
0078 21	1	LEISTUNGSSCHILD	Item discontinued(4931436037)	
0080 22	1	ANKER F.ELEKTROMOTOR	Item discontinued(4931436038)	
0081 23	1	BUCHSE	4931453359	4002395162567
0082 24	1	HAKEN	Item discontinued(4931436040)	
0083 25	1	HANDGRIFF KOMPL.	Item discontinued(4931436041)	
0084 26	1	ELECTRONIK-BAUSTEIN	Item discontinued(4931436042)	
0085 27	1	AUFNAHME	4931436647	4002395258734
0086 28	1	GETR-KASTENIS.LINKS	4931436044	4002395875672
0087 29	1	GETR-KASTENIS.RECHT	4931436045	4002395875689
0088 30	1	KURBELWELLE	4931436046	4002395875696
0089 31	1	MOTORGEHAEUSE	4931436047	4002395876303
0090 32	1	LAMPE	4931436048	4002395876310
0091 33	1	KABELSATZ	4931453362	4002395162598
0095 34	1	MOTOREINHEIT	Item discontinued(4931456542)	
0096 35	1	GEHAEUSE + SCHALTER	Item discontinued(4931456541)	
0700 36	1	TRANSPORTKASTEN	Item discontinued(4931436049)	
1000 37	1	SCHRAUBENSET	4931436032	4002395878369
38	1	M18B4 LI-ION AKKUMULATOR 4.0AH XXX	4932430063	4002395377244