

M18FLAG230XPDB-0 WINKELSCHLEIFER XXX

4933464113 - M18FLAG230XPDB-0 - 4000467890

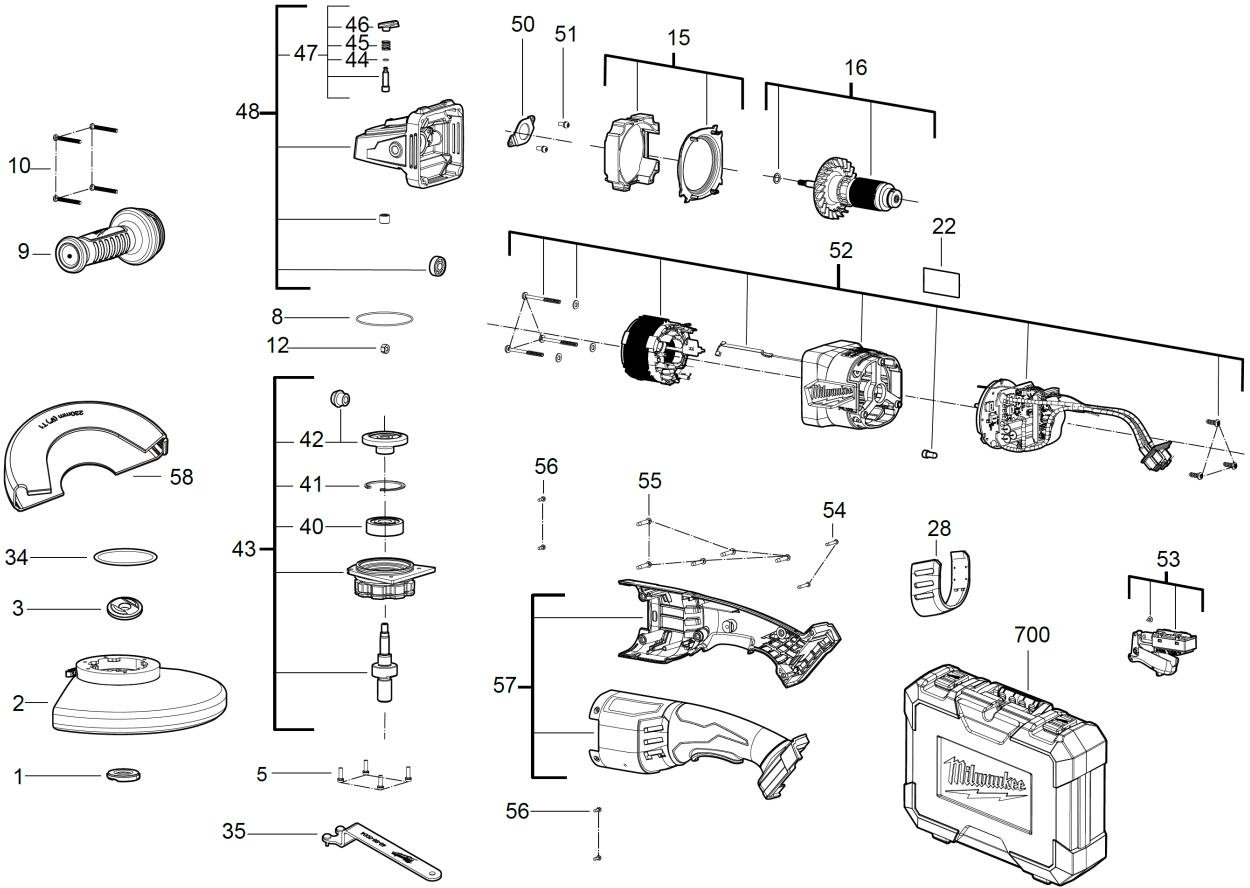



Position	Quantity	Description	Part number	EAN
0001 1	1	FIXTEC-MUTTER	4931466273	4058546274900
0002 2	1	SCHUTZ	4931465862	4058546239626
0003 3	1	FLANSCH	4931465842	4058546239428
0005 4	4	SCHRAUBE	4931465843	4058546239435
0008 5	1	O-RING	4931465844	4058546239442
0009 6	1	ZUSATZHANDGRIFF	4931435002	4002395855919
0010 7	4	SCHRAUBE	4931461254	4058546034269
0012 8	1	MUTTER	671686001	4002395824526
0015 9	1	RAHMEN	4931465845	4058546239459
0016 10	1	ANKER F.ELEKTROMOTOR	4931465846	4058546239466
0022 11	1	LEISTUNGSSCHILD	4931465863	4058546239633
0028 12	1	STAUBFILTER	4931465848	4058546239480
0034 13	1	O-RING	4931465849	4058546239497
0035 14	1	SCHLUESSEL	4931466274	4058546274917
0040 15	1	KUGELLAGER	4931465850	4058546239503
0041 16	1	SPANNRING	4931465851	4058546239510
0042 17	1	KEGELRADPAAR	4931465852	4058546239527
0043 18	1	ANTRIEB	4931465853	4058546239534
0044 19	1	O-RING	4931435006	4002395855957
0045 20	1	FEDER	4931435005	4002395855940
0046 21	1	DRUECKER	4931435004	4002395855933
0047 22	1	SPINDELARRETIERUNG	4931465854	4058546239541
0048 23	1	GETRIEBEKASTEN	4931465855	4058546239558
0050 24	1	HALTER	4931435039	4002395860364
0051 25	2	SCHRAUBE	4931465856	4058546239565
0052 26	1	ELEKTRONIK	4931465857	4058546239572
0053 27	1	SCHALTER	4931465858	4058546239589
0054 28	2	SCHRAUBE	660230017	4002395839742
0055 29	5	SCHRAUBE	4931453124	4002395152780
0056 30	4	SCHRAUBE	4931431788	4002395895717
0057 31	1	GEHAEUSE	4931465859	4058546239596
0058 32	1	TRENNSCHUTZHAUBE	Item discontinued(4931428099)	
0700 33	1	TRANSPORTKOFFER	4931465861	4058546239619