

M12FCOT-622X AK.-WINKELSCHLEIFER GB2

4933464620 - M12FCOT-622X - 4000467985

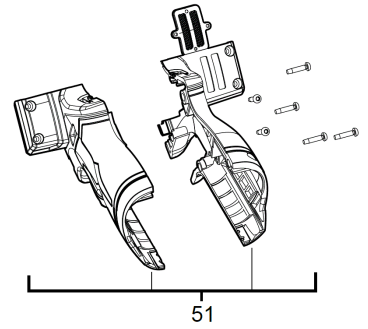

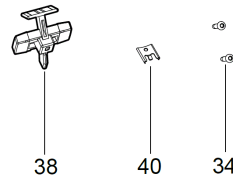
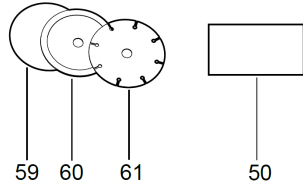
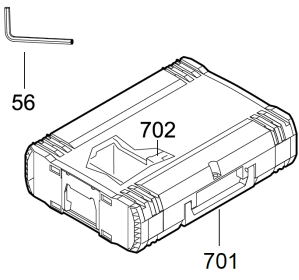
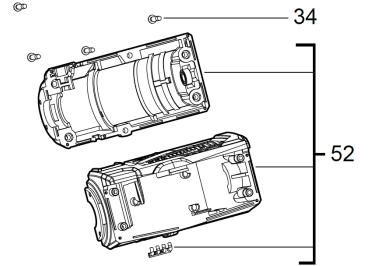
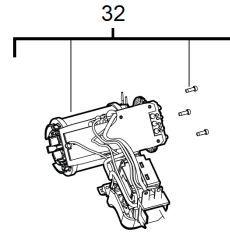
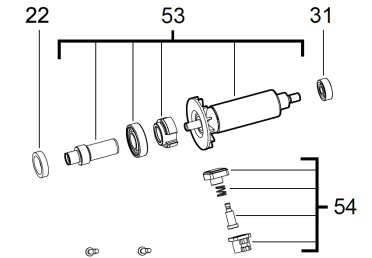
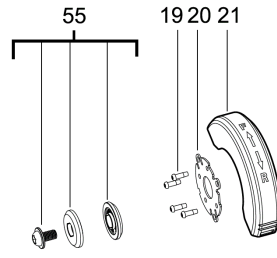
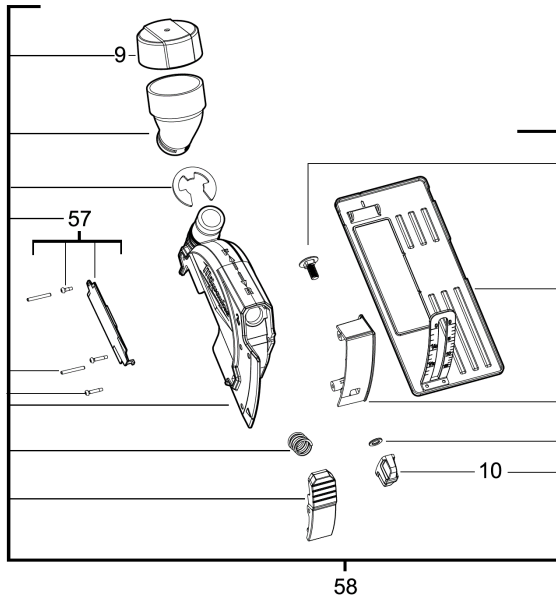

Position	Quantity	Description	Part number	EAN
0009 1	1	VERSCHLUSSKAPPE	4931466149	4058546273668
0010 2	1	EINSTELLKNOPF	4931466150	4058546273675
0019 3	4	SCHRAUBE	4931466151	4058546273682
0020 4	1	ARRETIERBLECH	4931466152	4058546273699
0021 5	1	SCHUTZ	4931466153	4058546273705
0022 6	1	FILZRING	4931466154	4058546273712
0031 7	1	LAGER	4931465281	4058546233815
0032 8	1	ELEKTRONIK	4931466155	4058546273729
0034 9	16	SCHRAUBE	660570005	4002395827329
0038 10	1	SCHALTER	4931466156	4058546273736
0040 11	1	VERBINDUNGSSTUECK	4931436292	4002395252909
0050 12	1	LEISTUNGSSCHILD	4931466157	4058546273743
0051 13	1	GEHAEUSE	4931466158	4058546273750
0052 14	1	MOTORGEHAEUSE	4931466159	4058546273767
0053 15	1	ANKER F.ELEKTROMOTOR	4931466160	4058546273774
0054 16	1	SPINDELARRETIERUNG	4931466161	4058546273781
0055 17	1	FLANSCH	4931466162	4058546273798
0056 18	1	SCHLUESSEL	4931436125	4002395878734
0057 19	1	ABDECKUNG	4931466163	4058546273804
0058 20	1	GLEITSCHUH	4931466164	4058546273811
0702 21	1	EINSATZ	4931466165	4058546273828
0059 22	1	Metalltrennscheibe SCS41 76 mm - 5PC	4932464717	4058546226626
0060 23	1	Diamanttrennscheibe DHTS 76 mm	4932464715	4058546226602
0061 24	1	HM-Trennscheibe 76 mm	4932464716	4058546226619
0701 25	1	HD Box Groesse 1	4932453385	4002395146376