

M18FHSAG150XPDB-0 AK.-WINKELSCHL. XXX

4933471083 - M18FHSAG150XPDB-0 - 4000469742

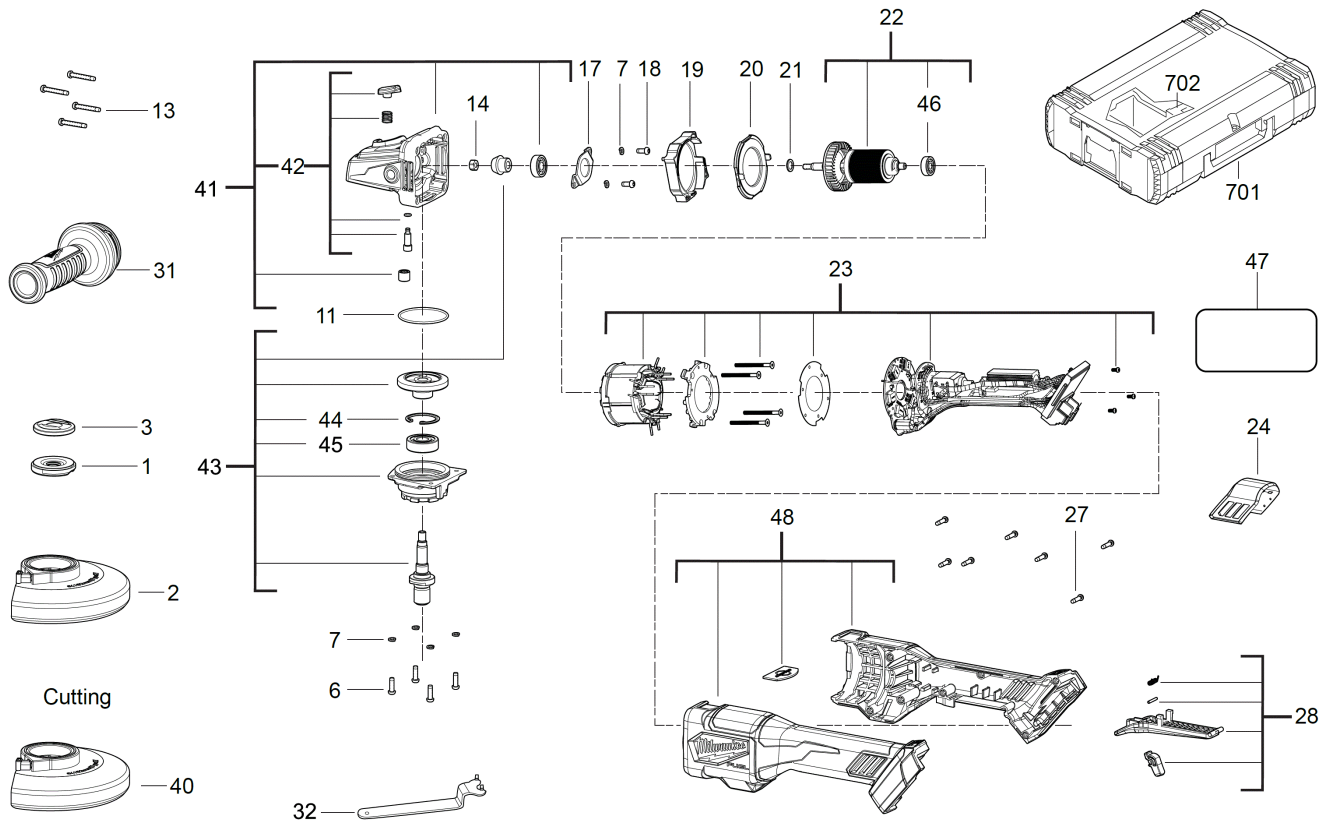



Position	Quantity	Description	Part number	EAN
0001 1	1	FIXTEC-MUTTER	4931466273	4058546274900
0002 2	1	SCHUTZ	4931466930	4058546281472
0003 3	1	FLANSCH	4931466915	4058546281328
0006 4	4	SCHRAUBE	4931435150	4002395859948
0007 5	6	SICHERUNGSRING	680866003	4002395823895
0011 6	1	O-RING	570699002	4002395824472
0013 7	4	SCHRAUBE	4931435023	4002395857302
0014 8	1	MUTTER	671686001	4002395824526
0016 9	1	KUGELLAGER	4931448373	4002395250769
0017 10	1	LAGERHALTER	672569001	4002395824533
0018 11	2	SCHRAUBE	660165015	4002395849826
0019 12	1	LUFTFUEHRUNGSRING	4931454165	4002395286393
0020 13	1	LUFTFUEHRUNGSRING	4931436011	4002395875368
0021 14	1	SCHEIBE	Item discontinued(632876001)	
0022 15	1	ROTOR	4931466916	4058546281335
0023 16	1	ELEKTRONIK	4931466917	4058546281342
0024 17	1	STAUBSCHUTZ	4931466918	4058546281359
0027 18	7	SCHRAUBE	660031017	4002395825189
0028 19	1	SCHALTERKAPPE	4931466919	4058546281366
0031 20	1	ZUSATZHANDGRIFF	4931435002	4002395855919
0032 21	1	SCHLUESSEL	4931466910	4058546281274
0040 22	1	SCHUTZHAUBEN-SET	Item discontinued(4931433698)	
0041 23	1	GETRIEBEKASTEN	4931466921	4058546281380
0042 24	1	SPINDELARRETIERUNG	4931466922	4058546281397
0043 25	1	SPINDEL SATZ	4931466923	4058546281403
0044 26	1	HALTERING	4931435476	4002395891658
0045 27	1	KUGELLAGER	4931466315	4058546275327
0046 28	1	KUGELLAGER	4931466924	4058546281410
0047 29	1	LEISTUNGSSCHILD	4931466942	4058546281595
0048 30	1	GEHAEUSE	4931466926	4058546281434
0701 31	1	HD Box Groesse 1	4932453385	4002395146376
0702 32	1	EINSATZ	4931466928	4058546281458