

# **M18FSAGV125XPDB-0 AKKU- WINKELSCHLEIF.XXX**

**4933499159 - M18FSAGV125XPDB-0 - 4000483289**

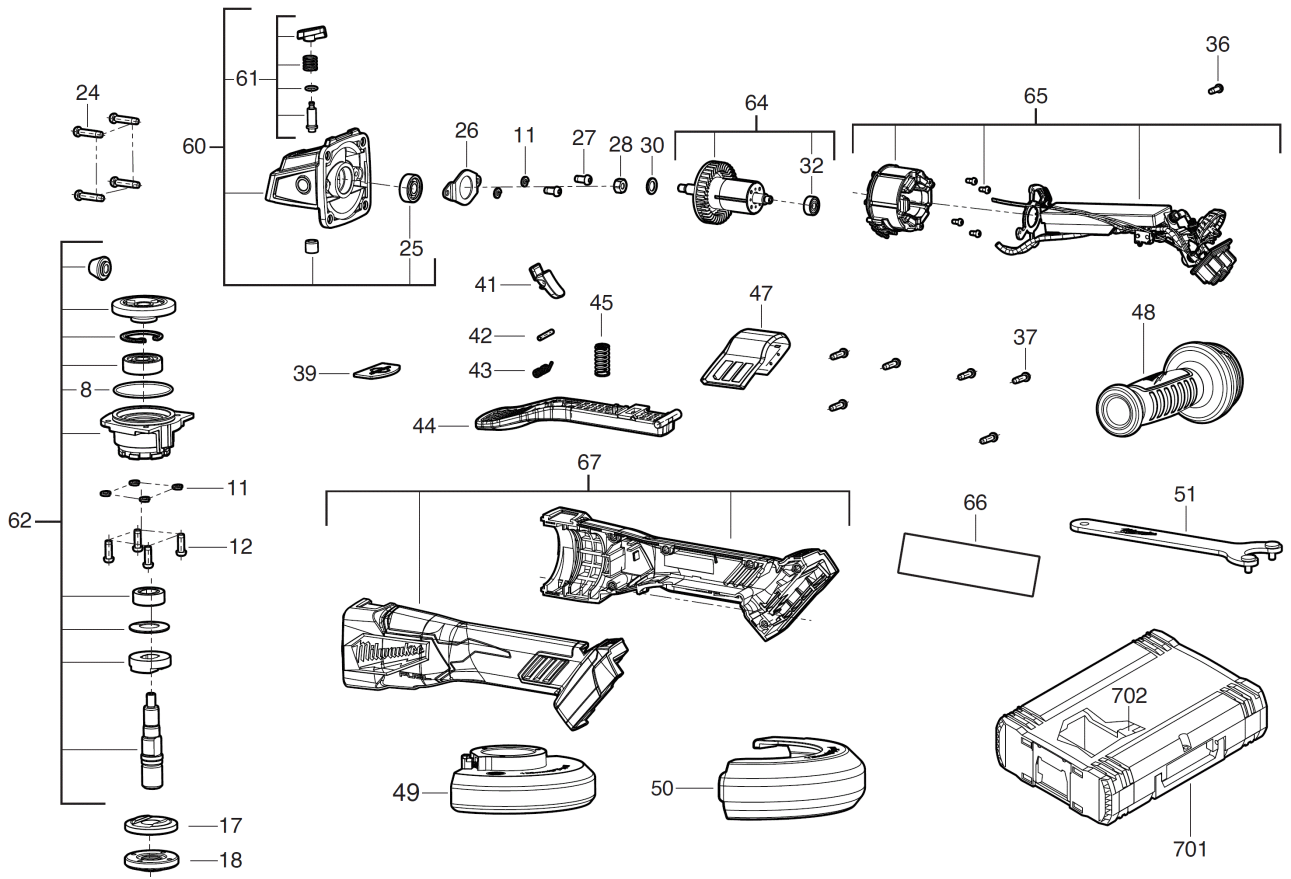

Position	Quantity	Description	Part number	EAN
0008 1	1	O-RING	4931479267	4058546385828
0011 2	6	SICHERUNGSRING	680866003	4002395823895
0012 3	4	SCHRAUBE	4931435150	4002395859948
0017 4	1	FLANSCH	4931479268	4058546385835
0018 5	1	FLANSCHMUTTER	4931441309	4002395887699
0024 6	4	SCHRAUBE	660024030	4002395826957
0025 7	1	KUGELLAGER	4931448373	4002395250769
0026 8	1	HALTER	4931479269	4058546385842
0027 9	2	SCHRAUBE	660165015	4002395849826
0028 10	1	MUTTER	671686001	4002395824526
0030 11	1	SCHEIBE	4931479270	4058546385859
0032 12	1	KUGELLAGER	4931479271	4058546385866
0036 13	1	SCHRAUBE	4931436686	4002395258260
0037 14	6	SCHRAUBE	660031017	4002395825189
0039 15	1	ABDECKUNG	4931479398	4058546387136
0041 16	1	DRUECKER	4931479404	4058546387198
0042 17	1	BOLZEN	4931454155	4002395285693
0043 18	1	FEDER	4931496284	4058546534219
0044 19	1	DRUECKER	4931479406	4058546387211
0045 20	1	FEDER	4931479407	4058546387228
0047 21	1	STAUBKAPPE	4931479275	4058546385903
0048 22	1	ZUSATZHANDGRIFF	4931435002	4002395855919
0049 23	1	SCHUTZ	4931479287	4058546386023
0050 24	1	TRENNSCHUTZHAUBE	4931479288	4058546386030
0051 25	1	SCHLUESSEL	4931479278	4058546385934
0060 26	1	GETRIEBEKASTEN	4931479402	4058546387174
0061 27	1	SPINDELARRETIERUNG	4931479280	4058546385958
0062 28	1	SPINDEL SATZ	4931479281	4058546385965
0064 29	1	ROTOR	4931479282	4058546385972
0065 30	1	FELD F. ELEKTROMOTOR	4931479408	4058546387235
0066 31	1	LEISTUNGSSCHILD	4931479414	4058546387297
0067 32	1	GEHAEUSE	4931479410	4058546387259
0701 33	1	HD Box Groesse 1	4932453385	4002395146376
0702 34	1	EINSATZ	4931479286	4058546386016