

MXFCOS350G20-0 AKKU-TRENNSCHLEIFER

4933499004 - MXFCOS350G20-0 - 4000497487

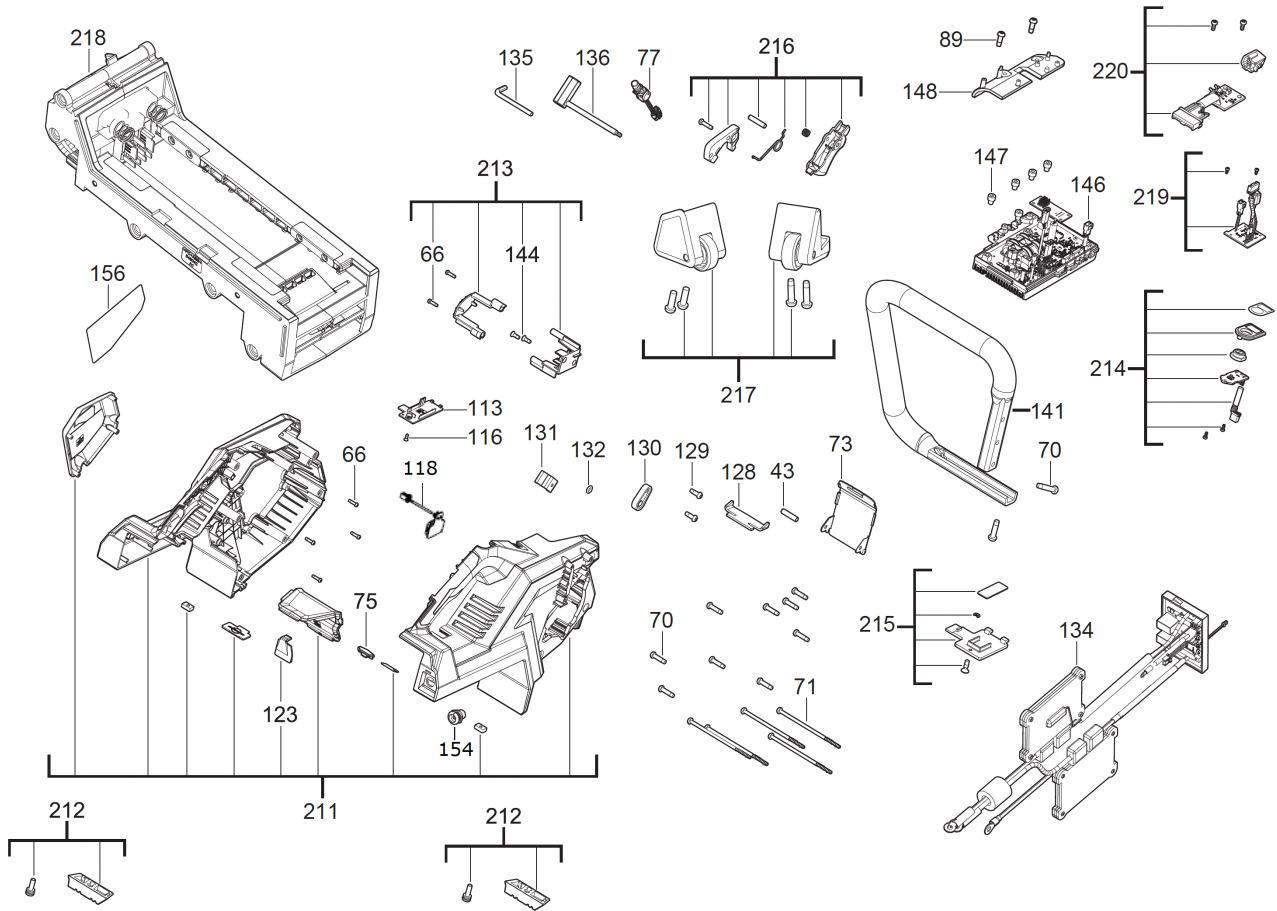

Position	Quantity	Description	Part number	EAN
0001 1	1	SCHRAUBE	4931472902	4058546332044
0007 2	2	ABSTANDSSCHEIBE	4931472908	4058546332105
0008 3	1	DICHTUNG	4931472910	4058546332129
0009 4	2	SCHRAUBE	4931465097	4058546231972
0011 5	1	SCHUTZVORRICHTUNG	4931496173	4058546533106
0014 6	2	SCHRAUBE	4931465285	4058546233853
0016 7	1	DICHTUNG	4931472915	4058546332174
0020 8	1	DICHTUNG	4931496174	4058546533113
0021 9	1	KUGELLAGER	4931496175	4058546533120
0022 10	1	LAGER	4931496176	4058546533137
0023 11	1	RETAINING RING	4931496177	4058546533144
0031 12	1	RIEMEN	4931496178	4058546533151
0033 13	2	MUTTER	4931472600	4058546329020
0037 14	4	SCHRAUBE	4931496179	4058546533168
0038 15	1	MUTTER	4931453988	4002395280551
0043 16	2	STIFT	4931496180	4058546533175
0051 17	1	FUEHRUNGSSCHEIBE	4931472947	4058546332495
0052 18	1	RIEMENSCHLEIFE	4931496181	4058546533182
0054 19	1	KUGELLAGER	4931496182	4058546533199
0055 20	1	RETAINING RING	4931496183	4058546533205
0056 21	4	SCHRAUBE	4931494114	4058546429959
0057 22	1	ANKER F.ELEKTROMOTOR	4931496184	4058546533212
0058 23	3	SCHRAUBE	4931472944	4058546332464
0065 24	1	GEHAEUSE	4931496185	4058546533229
0066 25	9	SCHRAUBE	660570005	4002395827329
0067 26	1	SCHUTZVORRICHTUNG	4931496187	4058546533243
0069 27	1	BOLZEN	4931496188	4058546533250
0070 28	12	SCHRAUBE	4931465543	4058546236434
0071 29	5	SCHRAUBE	4931472941	4058546332433
0073 30	1	SCHUTZ	4931496189	4058546533267
0075 31	1	LED LICHT	4931496190	4058546533274
0077 32	1	SCHALTER	4931496191	4058546533281
0089 33	2	SCHRAUBE	4931465326	4058546234263
0113 34	1	DECKEL	4931496192	4058546533298
0116 35	1	SCHRAUBE	4931496193	4058546533304
0118 36	1	STEUERSCHALTER KOMP	4931496194	4058546533311
0123 37	1	DECKEL	4931496195	4058546533328
0128 38	1	EINSATZ	4931496196	4058546533335
0129 39	2	SCHRAUBE	4931447515	4002395880539
0130 40	1	INBUS-SCHLUESSEL.	4931496197	4058546533342
0131 41	1	HALTER	4931496198	4058546533359
0132 42	1	O-RING	34404480	4058546072193
0134 43	1	ELEKTRONIK	4931496199	4058546533366
0135 44	1	SCHLUESSEL	4931472611	4058546329136
0136 45	1	SCHLUESSEL	4931472612	4058546329143
0141 46	1	GRIFF	4931507578	4058546600891
0144 47	2	SCHRAUBE	4931465063	4058546231637
0146 48	1	ELEKTRONIK	4931507224	4058546597351
0147 49	5	SCHRAUBE	4931496201	4058546533380
0148 50	1	DECKEL	4931496202	4058546533397

Position	Quantity	Description	Part number	EAN
0151 51	2	FLANSCH	4931496203	4058546533403
0153 52	2	FLANSCH	4931496204	4058546533410
0154 53	1	ANSCHLUSS	4931496205	4058546533427
0156 54	1	LEISTUNGSSCHILD	4931496206	4058546533434
0200 55	1	ADAPTER	4931496207	4058546533441
0201 56	1	GETRIEBEGEHAEUSE	4931496208	4058546533458
0202 57	1	SCHUTZVORRICHTUNG	4931496209	4058546533465
0203 58	1	SCHUTZVORRICHTUNG	4931496210	4058546533472
0204 59	1	ABDECKUNG	4931496211	4058546533489
0205 60	1	BAUSATZ	4931496212	4058546533496
0206 61	1	HALTER	4931496213	4058546533502
0207 62	1	BEFESTIGUNGSET	4931496214	4058546533519
0208 63	1	RIEMENSCHLEIBE	4931496215	4058546533526
0209 64	1	DECKEL	4931496216	4058546533533
0210 65	1	STATOR	4931496217	4058546533540
0211 66	1	GEHAEUSE	4931496218	4058546533557
0212 67	1	FUSS	4931496219	4058546533564
0213 68	1	QUERRIEGEL	4931496220	4058546533571
0214 69	1	ELEKTRONIK	4931496221	4058546533588
0215 70	1	DECKEL	4931496222	4058546533595
0216 71	1	DRUECKER	4931496223	4058546533601
0217 72	1	RAEDERPAAR	4931496224	4058546533618
0218 73	1	FUEHRUNGSSCHIENE	4931496225	4058546533625
0219 74	1	ELEKTRONIK	4931496226	4058546533632
0220 75	1	ELECTRONIK-BAUSTEIN	4931496227	4058546533649