

M18FHSAG125XPDB2-802X Winkelschleif IN2

4933493418 - M18FHSAG125XPDB2-802X - 4000497915

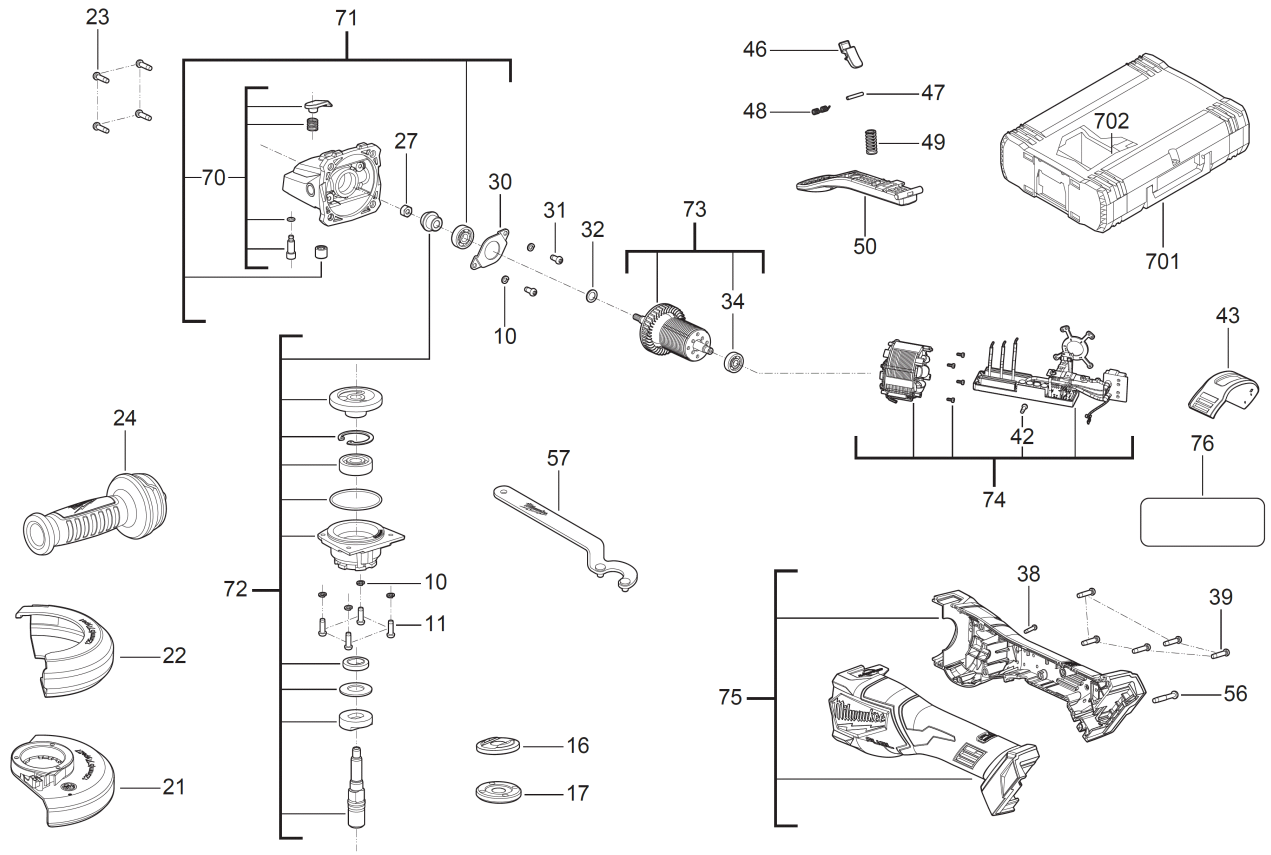



Position	Quantity	Description	Part number	EAN
0010 1	6	SICHERUNGSRING	680866003	4002395823895
0011 2	4	SCHRAUBE	4931435150	4002395859948
0016 3	1	FLANSCH	4931479268	4058546385835
0017 4	1	FLANSCHMUTTER	4931506775	4058546560898
0021 5	1	SCHUTZ	4931479287	4058546386023
0022 6	1	TRENNSCHUTZHAUBE	4931479288	4058546386030
0023 7	4	SCHRAUBE	4931496932	4058546552466
0024 8	1	ZUSATZHANDGRIFF	4931435002	4002395855919
0027 9	1	MUTTER	671686001	4002395824526
0030 10	1	LAGERHALTER	672569001	4002395824533
0031 11	2	SCHRAUBE	4931473732	4058546356088
0032 12	1	SCHEIBE	4931479270	4058546385859
0034 13	1	KUGELLAGER	4931466924	4058546281410
0038 14	1	SCHRAUBE	661047001	4002395824496
0039 15	5	SCHRAUBE	660031017	4002395825189
0042 16	1	SCHRAUBE	4931436686	4002395258260
0043 17	1	STAUBKAPPE	4931506778	4058546560928
0046 18	1	DRUECKER	4931479404	4058546387198
0047 19	1	BOLZEN	4931454155	4002395285693
0048 20	1	FEDER	4931496284	4058546534219
0049 21	1	FEDER	4931479407	4058546387228
0050 22	1	DRUECKER	4931496285	4058546534226
0056 23	1	SCHRAUBE	4931496283	4058546534202
0057 24	1	SCHLUESSEL	632145002	4002395823727
0070 25	1	SPINDELARRETIERUNG	4931506781	4058546560959
0071 26	1	GETRIEBEKASTEN	4931506782	4058546560966
0072 27	1	SPINDEL SATZ	4931506783	4058546560973
0073 28	1	ROTOR	4931506784	4058546560980
0074 29	1	ELEKTRONIK	4931506796	4058546561109
0075 30	1	GEHAEUSE	4931506786	4058546561000
0076 31	1	LEISTUNGSSCHILD	4931506797	4058546561116
0701 32	1	HD Box Groesse 2 XXX	4932498753	4058546526221
0702 33	1	EINLEGETEIL	4931506788	4058546561024