

# M18ONEFSAG115XPDB-552X A-WINKELSCH. GB2

4933478432 - M18ONEFSAG115XPDB-502XUK - 4000509160

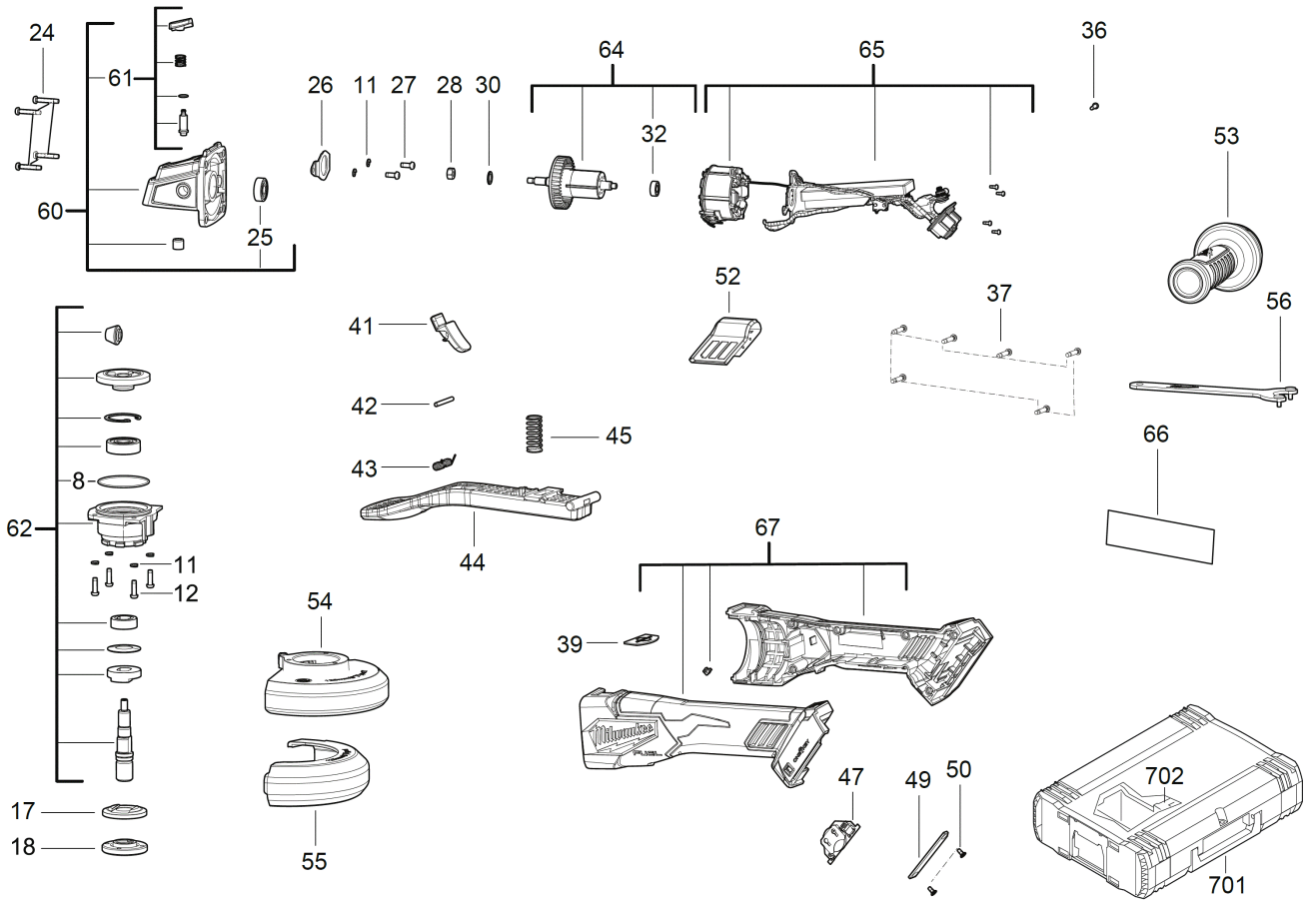



Position	Quantity	Description	Part number	EAN
0008 1	1	O-RING	4931479267	4058546385828
0011 2	6	SICHERUNGSRING	680866003	4002395823895
0012 3	4	SCHRAUBE	4931435150	4002395859948
0017 4	1	FLANSCH	4931479268	4058546385835
0018 5	1	FLANSCHMUTTER	4931441309	4002395887699
0024 6	4	SCHRAUBE	660024030	4002395826957
0025 7	1	KUGELLAGER	4931448373	4002395250769
0026 8	1	HALTER	4931479269	4058546385842
0027 9	2	SCHRAUBE	660165015	4002395849826
0028 10	1	MUTTER	671686001	4002395824526
0030 11	1	SCHEIBE	4931479270	4058546385859
0032 12	1	KUGELLAGER	4931479271	4058546385866
0036 13	1	SCHRAUBE	4931436686	4002395258260
0037 14	6	SCHRAUBE	660031017	4002395825189
0039 15	1	ABDECKUNG	4931479398	4058546387136
0041 16	1	DRUECKER	4931479404	4058546387198
0042 17	1	BOLZEN	4931454155	4002395285693
0043 18	1	FEDER	4931496284	4058546534219
0044 19	1	DRUECKER	4931479406	4058546387211
0045 20	1	FEDER	4931479407	4058546387228
0047 21	1	KONTAKTEINSATZ	4931479415	4058546387303
0049 22	1	ABDECKUNG	4931479416	4058546387310
0050 23	2	SCHRAUBE	4931465385	4058546234850
0052 24	1	STAUBKAPPE	4931479275	4058546385903
0053 25	1	ZUSATZHANDGRIFF	4931435002	4002395855919
0054 26	1	SCHUTZ	4931479276	4058546385910
0055 27	1	TRENNSCHUTZHAUBE	4931479277	4058546385927
0056 28	1	SCHLUESSEL	4931479278	4058546385934
0060 29	1	GETRIEBEKASTEN	4931479402	4058546387174
0061 30	1	SPINDELARRETIERUNG	4931479280	4058546385958
0062 31	1	SPINDEL SATZ	4931479281	4058546385965
0064 32	1	ROTOR	4931479282	4058546385972
0065 33	1	FELD F. ELEKTROMOTOR	4931479417	4058546387327
0066 34	1	LEISTUNGSSCHILD	4931507944	4058546626068
0067 35	1	GEHAEUSE	4931479419	4058546387341
0701 36	1	HD Box Groesse 1	4932453385	4002395146376
0702 37	1	EINSATZ	4931479286	4058546386016